



We believe that very few testing requirements are identical. We have created a test bench that is flexible to accommodate any testing setup from general to industry specific requirements.

The WorkBench has ergonomically designed instrument panel in vertical position and with sufficient space for working.

### Features

- Wheel (with locking mechanism) is provided at legs of workstation so that it can be easily moved.
- MCB is provided with AC supply for safety purpose.

### Sciencetech 827 Instrumentation WorkBench will comprises following instruments -

- 10 MHz AM / FM Function-Pulse Generators with 40MHz Frequency Counter
- 50MHz, 1GSa/s, 4CH Digital Storage Oscilloscope
- Dual Tracking DC Power Supply
- Soldering / Desoldering Station
- 3¾ Digital Multimeter

Single AC supply to power up all Instruments



MCB

Locking mechanism



### Front View

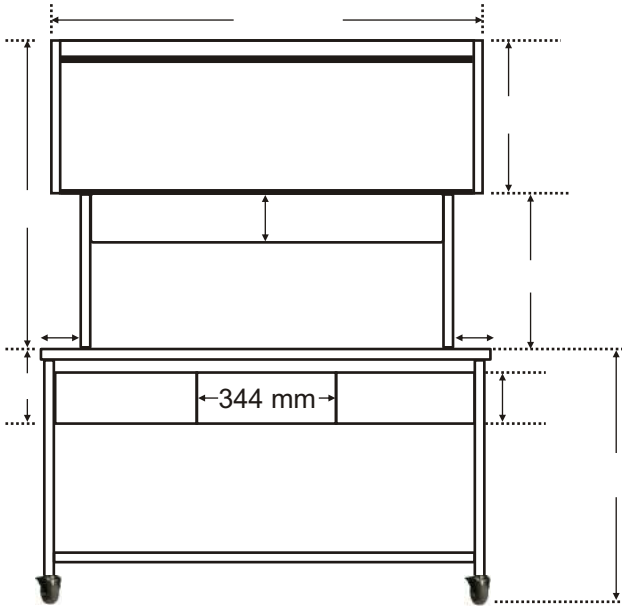

### Instruments included in standard WorkBench



Dual Tracking DC Power Supply



50MHz, 1GSa/s, 4CH Digital Storage Oscilloscope

### Back view

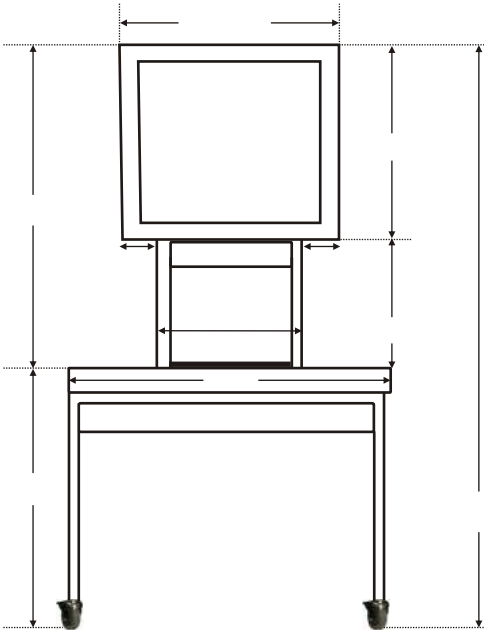

10 MHz AM / FM Function-Pulse Generators with 40MHz Frequency Counter



Digital Multimeter



Soldering / Desoldering Stations